

2009

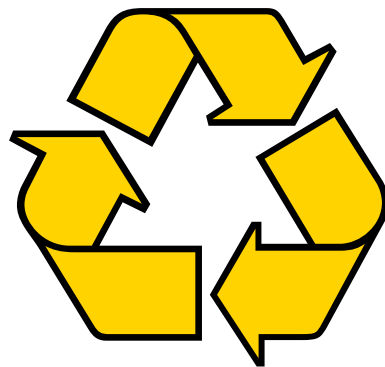

European Database
for Corrugated Board
Life Cycle Studies

FEFCO

Cepi ContainerBoard

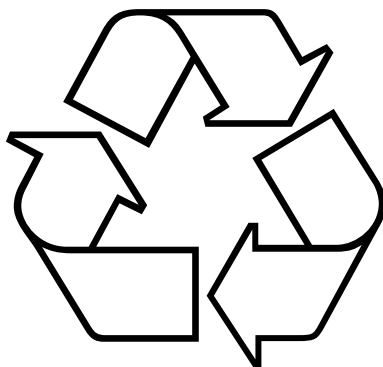

European Database for Corrugated Board Life Cycle Studies

FEFCO

Cepi ContainerBoard

Contents

Foreword	3
1. Description of production system	5
1.1. Paper production, a brief description of the process	5
1.2. Corrugated board production	8
2. Methodology questions	12
2.1. Boundaries	12
2.2. Closed-loop approach	13
2.3. Examples of calculation with a closed-loop approach, considering the total system	15
3. Data Description	18
3.1. Participating paper mills and corrugated board plants	18
3.2. Questionnaire, definitions, allocation of inputs and outputs to different paper products produced in the same mill	18
3.3. Weighted averages, "Best Average Environmental Practice"	19
3.4. Material input and output	20
3.4.1. Material inputs	20
3.4.2. Material outputs	21
3.5. Energy input and output	22
3.6. Water inputs and outputs	23
3.7. Transport	23
3.8. Emissions to air	24
3.9. Emissions to water	25
4. Data	27
5. Final Remarks	31
5.1. Updates	31
6. Definitions	32
Annex	33

Foreword

When looking at packaging, more and more customers and stakeholders want to know about the effects products they buy have on the environment. For almost 20 years, FEFCO (European Federation of Corrugated Board Manufacturers) and CCB (Cepi ContainerBoard¹) have been collecting data from the Industry in order to document the environmental impact of corrugated board and in order to demonstrate considerable improvements over the years.

This knowledge helps integrate environmental affairs into decision making. It supports product and process improvements, and the benchmarking encourages a responsible attitude of the industry towards the environment.

Through this report the Industry aims to make a contribution to the need for basic environmental data for LCA studies, available in a transparent way.

Technical experts from the Industry have worked together with LCA experts to update a database based on both, technical knowledge of paper and corrugated board production as well as on the requirements for LCA studies. The data collected from the Industry and aggregated in this report, result in a European database for life cycle studies.

The Annex of the report contains environmental data of the production of

- Corrugated base papers from primary fibres: Semichemical Fluting and Kraftliner (data from CCB)
- Corrugated base papers from recovered papers: Testliner, Schrenz and Wellenstoff (data from CCB)
- Corrugated board sheets and boxes (data from FEFCO).

The database handles the production sites as a black box: neither the details of the different processes in the production site nor the emissions etc. originating from energy production outside the mill, transport and waste treatment are included.

Cradle-to-grave datasets will be developed, including upstream and downstream processes as described in chapter 2. These will be made available from the FEFCO website (www.fefco.org) and from the CCB website (www.cepi-containerbord.org).

The data in this seventh edition represents the weighted averages of the inputs and outputs from the production sites per ton net saleable product (paper and corrugated board) for the year **2008**. The most common additives with a quantity of use equal or less than 0.5 % of the weight of the net saleable product have been updated too.

Looking at previous data collections, the values showed little change over the years and other LCA studies show that the impacts of these additives are relatively small.

Data on packaging and cores was not updated for 2008 for that same reason.

The report is available for interested parties on the condition that the data in this report may only be used for environmental studies such as Life Cycle Inventory Analysis, Life Cycle Impact Assessment as separate steps or as a whole Life Cycle Assessment.

The database may only be used for environmental studies regarding product development and improvement and the comparison of the entire system of corrugated board packaging with that of other materials. **The database may not be used for comparisons between the production of primary fibre and recovered fibre based materials as such.**

LCA methodology, with its systematic, scientific approach, gives an insight of the environmental impact that a product may have **on a case-by-case basis**.

When LCA data is used to make comparative studies, a specific scenario is chosen and the result can and will vary depending on various parameters. It should be clearly understood that, whatever the

¹ In the past, the project was a joint undertaking by three associations FEFCO, GEO (European Association of makers of Corrugated Base Papers) and ECO (European Containerboard Organisation). Now GEO and ECO have merged to become Cepi ContainerBoard.

outcome of a comparative study, the conclusion should not and cannot be generalized.

It is therefore not recommended to use a single message from a comparative LCA study as the basis for lobbying activities.

According to ISO 14044, allocation of the impacts of primary fibre production (the cradle) and waste treatment (the grave) of wood fibre to the phases in between the cradle and the grave of the life cycle should be avoided, wherever possible. In our case this is done by expanding the product system and considering the expanded system with a closed-loop approach.

The two Associations intend to regularly update the database. The user of the database should therefore enquire of either of the two Associations whether it is the latest edition of the database report prior to using the information enclosed.

We are grateful for the positive response and useful comments we have received from users of the previous editions of the Database reports. We want to thank all participants from the Industry for providing the necessary input from their plants.

We welcome comments on this report and experiences from users of the database as a contribution to the regular updates!

November 2009

Angelika Christ
FEFCO

Klaus Spielmann
Cepi ContainerBoard

1. Description of production system

1.1. Paper production, a brief description of the process

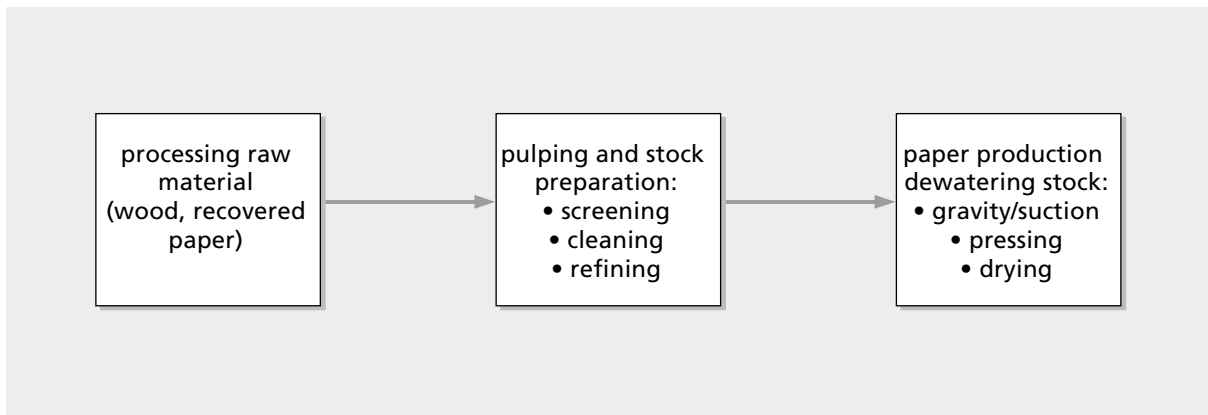

Fig. 1a Outline of paper production process

Raw materials processing

Wood

The process for the production of Kraftliner and Semichemical Fluting starts with wood coming from the forest to the mill. Most of the wood is delivered to the mill in the form of pulpwood logs but also a substantial part is bought as wood chips from saw mills nearby. The pulpwood logs have to be debarked and chipped before further processing. Therefore the logs have to pass through a barking drum and a chipper.

The chips produced are screened to take away wood dust formed as well as oversized chips and knots. The oversized chips are reprocessed to get proper chip dimensions and brought back to the chip flow. The chips are stored in a chip pile before processing in the pulp department.

Recovered paper

The raw material for Testliner and Wellenstoff, recovered paper, is delivered as bales, and kept on stock by grade.

With a pre-selection method, it is possible to determine the suitability of a certain recovered paper mix for the stock preparation and paper process. The stock preparation is done in accordance with a recipe for each paper grade and grammage. The grades of recovered paper are put on the conveyor to the pulper in the ratio mentioned in the recipe.

Pulping and stock preparation

Pulping and stock preparation of primary fibres

The wood chips are normally cooked to pulp for Kraftliner production by the kraft cooking process. It is a highly alkaline cooking process with caustic soda and sodium sulphide as active cooking chemicals. The cooking takes place in a digester at high pressure and a temperature of 150 -170 oC. The pulp yield is normally around 55% i.e. 1000 kg of dry wood gives 550 kg of pulp.

For Fluting production the wood chips are cooked to pulp by the Semichemical cooking process. It is a slightly alkaline cooking process most commonly with sodium sulphite and sodium carbonate as active cooking chemicals. The pulp yield is normally around 80%.

The spent cooking liquor is drained off and washed out from the pulp. It contains the wood substance dissolved during the cooking together with the spent cooking chemicals. The spent liquor is concentrated and burnt for steam production and recovery of cooking chemicals.

The pulp produced is defiberized in refiners, screened and washed before being sent to the paper mill.

In the paper mill the pulp is mechanically treated in beaters to improve fibre-to-fibre bonding and strength of the paper. The pH level of the pulp

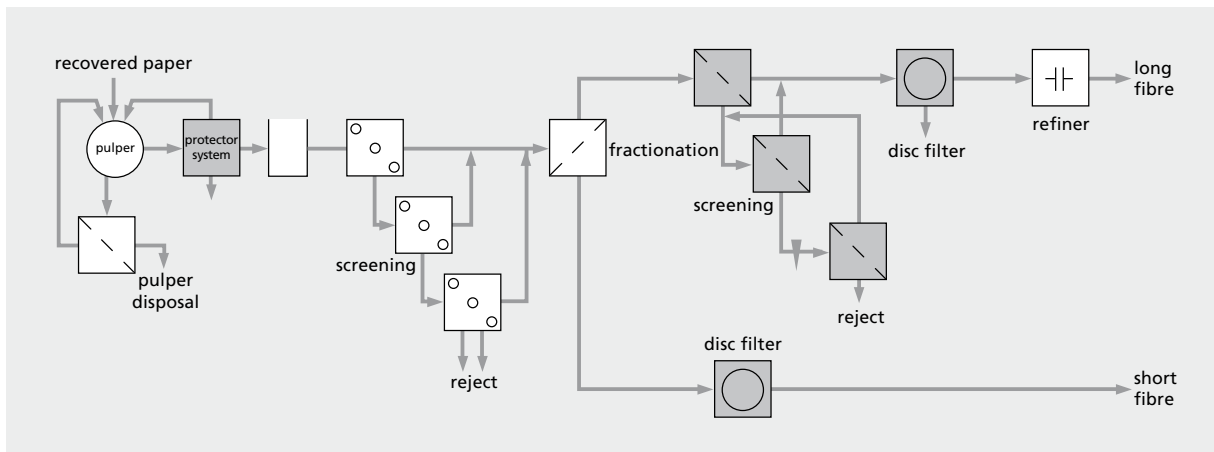

Fig. 1b Example of stock preparation in recovered paper processing

slurry is adjusted with acid and some additives are added to facilitate the paper production. Functional chemicals, fillers and other pulps i.e. recovered paper pulp may also be added to give the final paper the properties required. Finally the pulp slurry is screened and diluted before being sent to the head box of the paper machine.

Pulping and stock preparation of recovered fibres

In the pulper the blend of dry, baled paper is converted into a pumpable suspension of fibres. This is achieved by submerging the bales in water and agitating the mixture so that the paper is wetted and broken up to form a suspension.

Large contaminants, which do not readily break up, can be removed from the pulper using a “ragger” or “junker” which is a tool to remove large pieces of textiles, plastics etc., which are caught on the original wires of the bales.

Remaining undesirable elements in the raw material are eliminated from the pulp by screening and cleaning. After that the pulp may undergo a disperging treatment.

For this treatment the pulp is dewatered by wire or screw presses and concentrated to 25-30% and heated by steam to 80 -110 °C. The hot pulp is passed through a type of deflaker (kneads the pulp) moving through the gap between a stationary and a rotating disk with a lot of teeth.

During the treatment contaminants such as hot melt, wax, ink and coating binders loosen from the fibres and together with small fragments of paper are reduced to fine particles (“disperged”) which therefore are no longer visible. The dis-

perging treatment also has a positive influence on certain paper characteristics and fibre bonding capability.

Pulp for recovered fibre based paper for corrugated packaging does not normally undergo a de-inking process.

The dosage of additives can either take place during the stock preparation process, just before/or in the headbox, on the wire section (e.g. by spraying) or by surface treatment on the size press.

Paper production

The stock passes through one or two head boxes onto the paper machine. The paper is formed from the head box onto the wire and dewatered through the wire primarily by the action of gravity and suction. Further dewatering by mechanical means takes place in the press section where water is taken out of the sheet by pressing between felts. The final drying takes place in the drying section of the machine where the sheet runs against steam heated cylinders to get its final dryness of 91-93%. The collected water is reused for diluting the thick stock coming from the stock preparation.

Semichemical Fluting is a paper with just one ply and therefore the paper machine only has one head box and one wire. Kraftliner is normally a two ply product and therefore requires a paper machine with two head boxes and normally also two wires. The base brown ply contains the internal machine broke pulp in addition to wood fibres

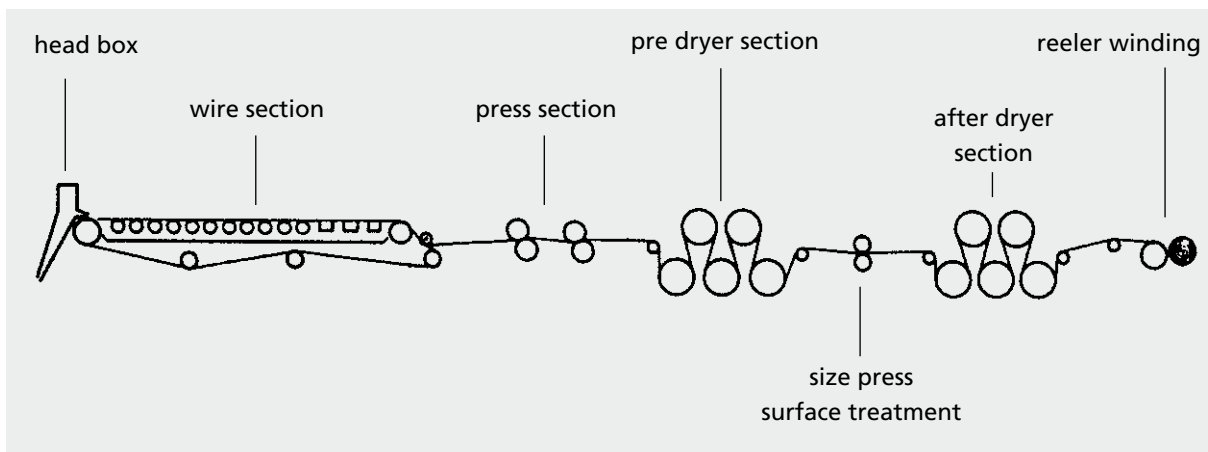

Fig. 1c Example of paper machine for containerboard grades

from the integrated pulp production and could also contain recovered paper pulp. The top ply is normally wood pulp from the integrated pulp production that is more refined and cleaner to give the top surface the right characteristics and printability. For white surface grades bleached fibres are of course used for the top ply.

Testliner mostly consists of two plies of paper. Depending on the type of Testliner the fibre composition of mixes of types of recovered paper can be different in each layer. In general a better grade of mix is used for the upper layer for reasons of appearance and strength. In order to increase its strength Testliner receives a surface treatment in the size press. This involves the application of a starch solution to one or both sides of the sheet. The top ply of Testliner is given an even, mostly brown colour by colouring the mass or by means of the size press treatment. The addition of special additives (in the mass or by means of the size press) makes it possible to produce Testliners with special properties such as extra water-repellent, low-germ and anti-corrosion grades.

Wellenstoff can be a one ply or two ply product. Usually a size press treatment with a starch solution is applied in-line on the paper machine in order to obtain sufficient strength and stiffness properties.

The most common surface treatment of recovered fibre based corrugated board materials is done by a size press. Essentially a size press comprises two revolving rubber covered rolls, pressed together, through which the paper web passes. In the nip formed by the rolls there is a starch solution. The

paper absorbs some of this solution, is pressed between two rolls and goes into the "after dryer" section of the paper machine in order to evaporate from the paper excess water absorbed from the starch solution in the size press.

After the paper machine there is a slitter winder where the big jumbo reel from the paper machine is rewound and cut down to customer reel formats according to customer orders. Finally the reels are weighed, marked, labelled and prepared for shipment to the customer, the corrugated board industry.

1.2. Corrugated board production

Corrugated Board is manufactured from a number of specially conditioned layers of recycled and/or virgin papers, called Fluting Medium and Linerboard. Reels of Fluting Medium and Linerboard are fed into a machine called a Corrugator. The Fluting Medium paper is conditioned with heat and steam and fed between large corrugating rolls that give the paper its fluted shape in the Single Facer. Starch is applied to the tips of the flutes on one side and the inner liner is glued to the fluting. The corrugated fluting medium with

one liner attached to it is called single face web and travels along the machine towards the Double Backer where the single face web meets the outer liner and forms corrugated board. A number of layers of single faced web may be built up to produce double and triple wall corrugated board. The corrugated board is slit into the required widths and cut into sheets which are then stacked or palletised.

The final stage of the process consists of printing and then slotting, folding and gluing the corrugated board to manufacture a corrugated box.

Various structures of corrugated fibreboard are (ISO 4046):

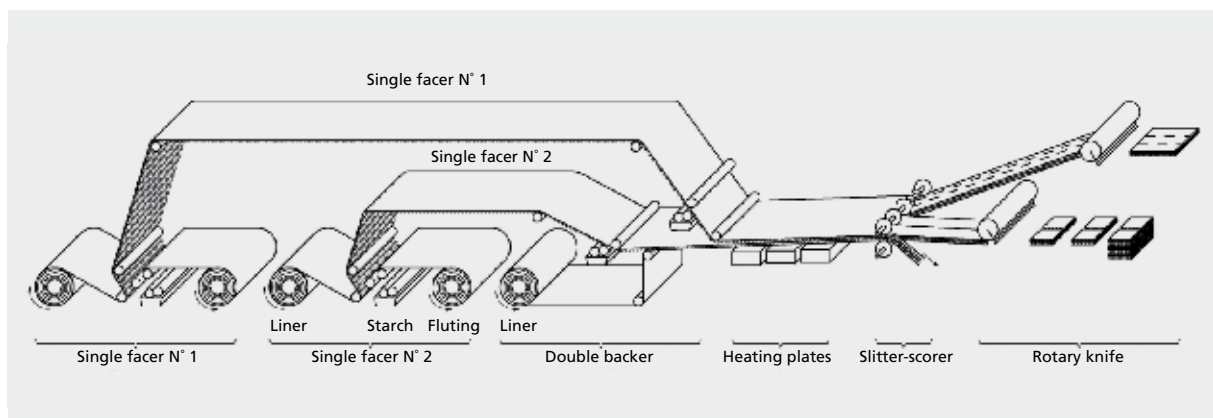
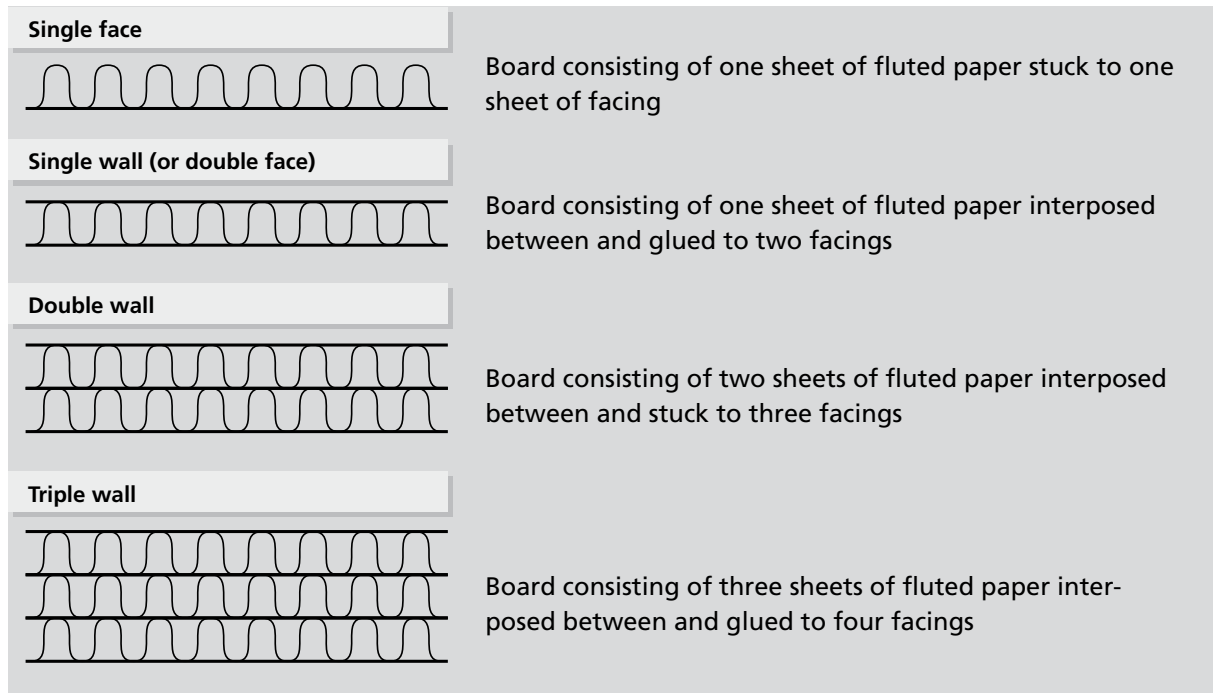

Figure 1d Corrugated board production

Most boxes are also printed in one or more colours to identify the product they are going to contain, the product manufacturer, the box manufacturer and also bar codes providing other information regarding the distributed goods. Different operations are carried out according to the customer's specification and according to the type of packaging. The two main categories are the regular slotted box and the die-cut box. The latter concerns packaging that requires a very precise cutting and which can have a complex design.

Most of the regular slotted boxes are produced with an in-line flexographic Printer/Slotter/ Folder/ Gluer which, in one operation, prints, cuts, folds and glues the blank into its final shape.

The die-cut boxes are manufactured on a die-cutter (rotary or flatbed) which cuts and creases the board.

After converting the corrugated packaging is put on a pallet and delivered to the customer.

A corrugated box is composed of layers of paper: liner (linerboard) and fluting (corrugating medium). The four major paper grades used for the production of corrugated board boxes are Kraftliner, Testliner, Semichemical Fluting and Wellenstoff (recycled fibre based fluting) for which the data are found in the database.

The composition of the corrugated box depends on the function that it has to fulfil.

The consumption of liner and fluting can be calculated from the dimensions of the box, grammage of the liners and fluting, what kind of flute i.e. wave type is used and weight of the sheet before die cutting. Different wave types lead to different heights of the corrugated layer. In table 1 indicative figures are given for different flute types

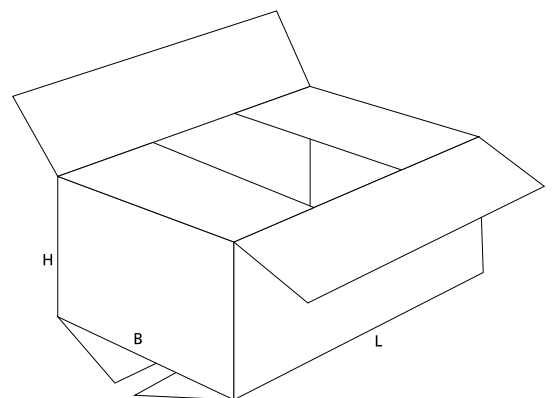
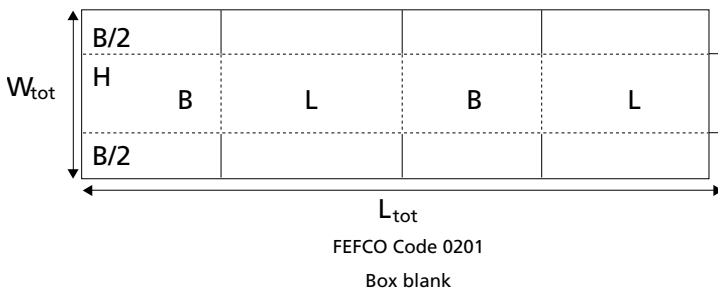

Table 1. Flute types

Flute	Height of the corrugated member* mm	Flutes/m length of the corrugated board web	Take-up factor	Glue consumption g/sqm, glue layer
A	4,8	110	1,50-1,55	4,5-5,0
B	2,4	150	1,30-1,35	5,5-6,0
C	3,6	130	1,40-1,45	5,0-5,5
E	1,2	290	1,15-1,25	6,0-6,5
F, G, N	0,5-0,8	400-550	1,15-1,25	9,0-11,0

* facings excluded

The take-up factor gives the amount of fluting per sqm of corrugated board: i.e. for a C-flute the amount of fluting in the corrugated board will be about 1,4 sqm/sqm corrugated board.

Example: FEFCO Code 0201
 box weight: 650 g,
 dimensions : 575 x 385 x 225 mm (L x B x H)
 corrugated board C flute
 facings: Kraftliner 175 g/sqm, Testliner
 175 g/sqm
 corrugating
 medium: Wellenstoff 140 g/sqm

The composition of the corrugated board is then:

		g/sqm
Kraftliner		175
Wellenstoff	1,43 x 140 =	200
Testliner		175
Glue	2 x 5 =	10
Grammage		560

The corrugated board manufacturer can give the weight of the sheet before die-cutting. For a standard type construction the weight can also be calculated using the International Fibre Board Case Code published by FEFCO and ESBO (European Solid Board Organization). In this code the form of the box blank is shown and by using the box dimensions it is possible to calculate the total length and width of the blank. Adding a 20 mm broad strip to the edges of the blank gives a fair estimate of the sheet area before die-cutting.

In the example $L_{tot} = 1,95$ m and $W_{tot} = 0,61$ m. The dimensions of the sheet are:

$$A_{sheet} = (1,95 + 0,04) \times (0,61 + 0,04) = 1,2935 \text{ sqm}$$

and the weight:

$$M_{sheet} = 1,2935 \times 560 = 724 \text{ g}$$

Assuming 3 % as corrugator trimmings (i.e. $\eta_{corrugator} = 0,97$, a common value for modern corrugators), the consumption of liner and fluting can be calculated as follows:

		g/box
Kraftliner	$175 * 1,2935/0,97 =$	233
Wellenstoff	$200 * 1,2935/0,97 =$	267
Testliner	$175 * 1,2935/0,97 =$	233
Glue	$10 * 1,2935/0,97 =$	13
		746

Total losses = $746 - 650 = 96$ g/box = 12,9% of the input.

Please note that this is only an example of a particular box of a certain standard type construction. Corrugated board boxes are far from standardised. They show a huge variation in composition, design and appearance. Boxes are tailor made to fit the box users need and requirements set by the product to be packed.

Table 2 shows examples of different boxes.

Since standard boxes do not exist, the database is set up in a flexible way giving the user the possibility to make calculations for any composition he wants and using his own assumptions on transport distance, waste management scenario's etc.

Table 2. Examples of boxes

Type of box	FEFCO Code CF2	FEFCO Code CF1	FEFCO Code 422	FEFCO Code 0201	FEFCO Code 0406	FEFCO Code 0459	FEFCO Code 0201
Product in box	fruit & vegetables 6 kg	fruit & vegetables 10 kg	lettuce 10 pcs 6 kg)	500 g powder milk cartons	6x 750 ml champagne bottles	24 x 250 ml beer cans	12 x 16 tissue handkerchiefs
Net box weight	391 g	686 g	557 g	443 g	375 g	76 g	159 g
Outside dimensions	400 x 300 x 145 mm	600 x 400 x 180 mm	595 x 395x 165 mm	490 x 385 x 200 mm	335 x 256 x 211 mm	365 x 244 x 63 mm	251 x 160 x 332 mm
Number of boxes from sheet (x)	4	2	3	1	2	8	1
Sheet dimensions for x boxes	1410 x 1650 mm	1190 x 1550 mm	1307 x 2183 mm	585 x 1790 mm	979 x 1154 mm	1012 x 1510 mm	492 x 852 mm
Net sheet surface for x boxes	2,33 m ²	1,84 m ²	2,85 m ²	1,05 m ²	1,13 m ²	1,53 m ²	0,42 m ²
Board composition 1)	EB KL140/SCF110/ SCF110/SCF125/ KL125	BC KL140/SCF125/ SCF125/SCF125/ KL140	BE WKL125/WS105/ WS105/WS105/ TL135	C MTL140/WS105/ TL135	EB WKL140/WS110/ WS110/WS125/ TL125	B TL135/WS105/ TL135	B TL120/WS105/ TL120
Paper consumption sheet grammage	g/m ²	g/m ²	g/m ²	g/m ²	g/m ²	g/m ²	g/m ²
Outer liner	140	140	125	140	140	135	120
Fluting liner	134.2	166.3	139.7	151.2	134.2	139.7	139.7
Middle liner	110	125	105	135	110	135	120
Fluting liner	166.3	180	128.1		166.3		
Inner liner	125	140	135		125		
Grammage board	675 g/m ²	751 g/m ²	633 g/m ²	426 g/m ²	675 g/m ²	410 g/m ²	380 g/m ²
Net weight sheet for x boxes	1571 g	1386 g	1805 g	446 g	763 g	626 g	159 g
Net sheet weight 1 box	393 g	693 g	602 g	446 g	382 g	78 g	159 g
Composition paper and glue per box	g/box	g/box	g/box	g/box	g/box	g/box	g/box
Kraftliner	154	258	119	0	79	0	0
Semichemical Fluting	239	435	0	0	0	0	0
Testliner	0	0	128	288	71	52	101
Wellenstoff	0	0	355	158	232	27	59
Starch	19	30	17	10	13	2	5
Sheet weight + glue for 1 box	412	723	619	456	395	81	165

Take up factors used: E : 1,22 - B : 1,33 - C : 1,44
 KL : Kraftliner, SCF : Semichemical Fluting, MTL : Mottled Testliner, WKL : White Kraftliner, TL : Testliner number is paper grammage g/m²

2. Methodology questions

2.1. Boundaries

This report gives the inputs and outputs from the paper mills and the corrugated board plants separately. Inputs and outputs from the processes mentioned in the grey boxes in fig. 2 are included in the Database.

To make a complete LCA study supplementary data are needed (outside the grey boxes, text in

italics in fig 2) such as environmental impacts of precombustion, electricity production for the public grid, transport and waste treatment.

The use of the corrugated box (transportation, protection and identification of the product it contains) is not included in the Database. The user has to use the design of the box and details on its transportation containing the product to calculate the full life cycle of the box.

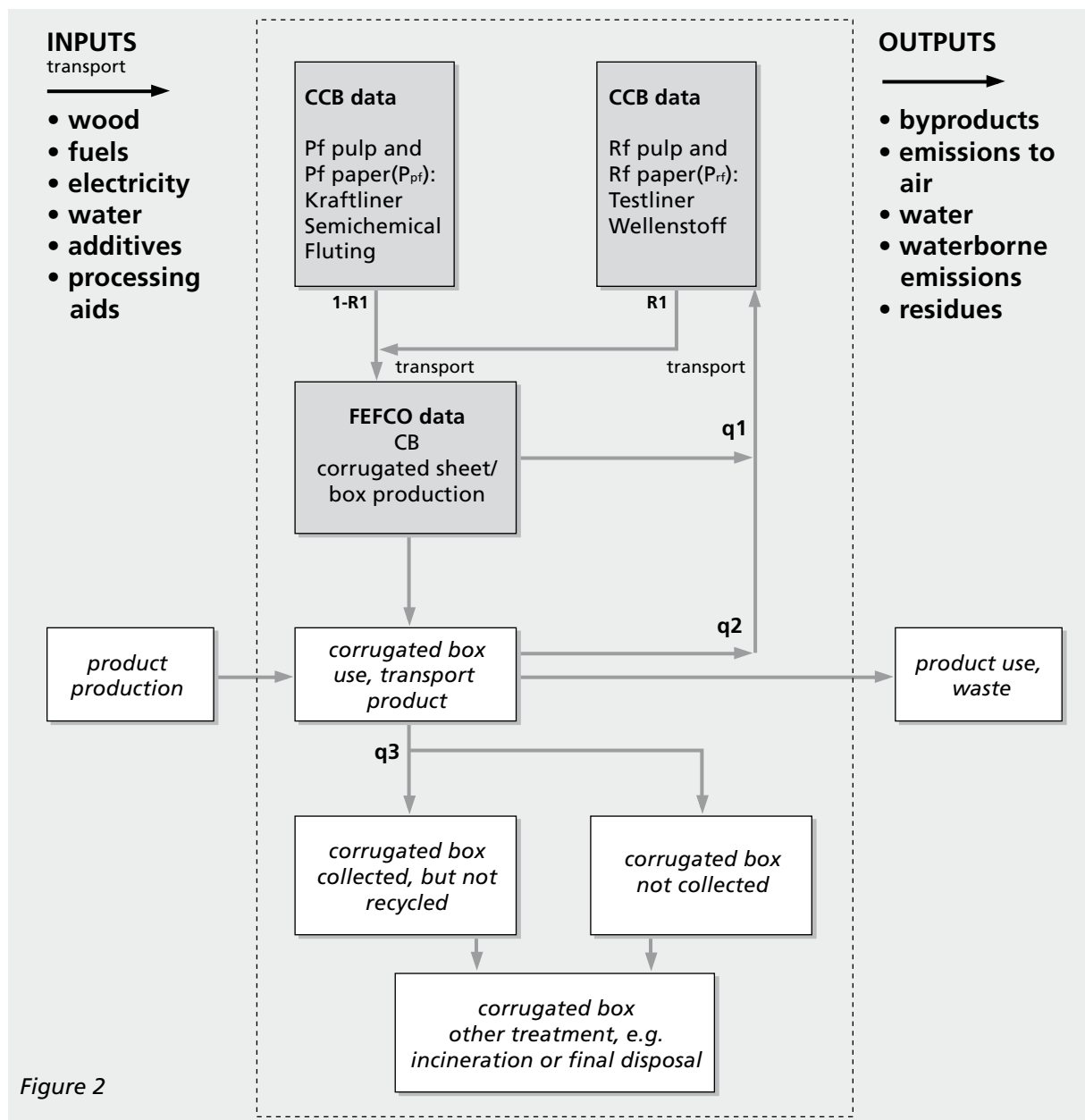

Pf paper : primary fibre based pulp and paper production
Rf paper : recovered fibre based pulp and paper production
CB : corrugated sheet and box production
 $R1$ = total of recovered fibre in paper input for corrugated board production/total paper used for corrugated board production
 r_{sh} : equal to the rate of shavings, in % of the paper used for the production of corrugated sheet
 $R2$ = the recovery rate of corrugated board after use

$q1$ = quantity of collected shavings calculated as follow:
 $[r_{sh} \times \text{total paper input for corrugated board production}]$
 $q2$ = quantity of collected corrugated board after use which is recycled (calculated as $R2 \times \text{total corrugated board packaging deliveries}$)
 $q3$ = quantity of collected corrugated board after use which is not recycled (calculated as $[1 - R2] \times \text{total corrugated board packaging deliveries}$)

2.2. Closed-loop approach

When performing environmental studies such as Life Cycle Inventory Analysis for products made from wood fibres, the whole life cycle of the fibres must be evaluated from the fibre production until the fibre is lost as waste, normally after having been recycled several times.

Recycling may either be characterised as a closed-loop or an open-loop process. Closed-loop recycling returns the material to the original process and open-loop recycling refers to a product or component going from one system to another for use as raw material in the production of a different product.

To study and analyse an open-loop system, the inputs and outputs from the linked systems have to be studied. This however is not practical in the case of paper recycling, since the linked systems are extremely complex and very difficult to survey.

To simplify the system, recycling of corrugated board may be looked upon as processing of the primary fibre after use in corrugated board or as raw material processing for the secondary product (or recycled products), also used in corrugated board. At present this is a fairly just simplification seeing that the main raw material for the recovered paper mills is used corrugated board, thus flows in and out of the system of other kinds of paper are ignored.

The problem that remains after this simplification is that choices have to be made to allocate the impacts to the primary fibre based paper and the recovered fibre based paper:

- the impacts of the primary fibre pulp production and the final waste treatments
- the avoided impacts resulting from the recycling.

However the need for allocation can be avoided (as advised by ISO 14044) by carrying out the calculations as if the recovered material is used in the same life cycle, i.e. by considering the recycling system as a closed-loop. In this case the collected fibres displace the input of primary fibres.

A closed-loop approach requires that the total system is considered during a certain period of time and a specific geographic area. A simplified system for a closed loop corrugated board packaging system is given in figure 2.

There are different definitions for recycling and recovery (which could mean collection of waste or treatment of waste), depending on the application. This of course leads to the publication of different recycling/recovery rates.

For example CEN 13440:2003 describes a procedure for calculating the rate of material recycling to demonstrate compliance with the recycling targets given in the Packaging and Packaging Waste Directive 94/62/EC (as amended by 2004/12/EC).

For the system described in figure 2, fibres are recovered (in the sense of collected) from shavings from the production of corrugated board and from collected corrugated board after use, and following that are recycled in a papermaking process to become new paper.

The recycled fibre content R1 for this report is defined as total recovered fibre recycled from shavings (q1) as well as from used corrugated boxes (q2) divided by the total paper production used for corrugated board production.

- q1 is defined as the weight of production shavings from corrugated board production divided by the weight of the base paper used for the corrugated board production. These production shavings are always recycled. This average figure for Europe can be found in the data from FEFCO (chapter 4. Data, under residues: paper, board recycled). It follows that the percentage of shavings $r_{sh} = 0,148 \text{ ton}/1,09 \text{ ton} = 14\%$ of the input of the base papers is recycled from shavings.

- q2 is defined as the weight of collected corrugated board after use effectively recycled divided by the weight of the base paper used for corrugated board production. Recycling is the common practice for the collected (and if necessary sorted) corrugated board, but it may be that fibres are lost from the loop because not all corrugated packaging is collected. For corrugated board that is not recycled, other recovery options, such as incineration with energy recovery may take place. According to an estimation based on CEPI statis-

Definitions and calculations of recovery and recycling for regulations.

Definitions of recovery and recycling EN 13193

Definitions set for the Directive on packaging and packaging waste 94/96/EC.

Recycling: reprocessing in a production process of the waste materials for the original purpose or for other purposes including organic recycling but excluding energy recovery.

Material recycling: recycling by means other than organic recycling

Packaging waste: any packaging material covered by the definition of waste in Directive 75/442/EEC, excluding production residues. Note Packaging or packaging materials which fall out of the commercial cycle or out of the chain of utility. Such items of material may be subject to recovery processes or may be sent for final disposal.

Recovery: any of the applicable operations provided for in annex II B to Directive 75/442/EEC [Directive 94/62/EC]. Note An operation which intentionally divert waste from final disposal. The principal operations used for packaging are recycling (including composting) and energy recovery.

Definitions for recovery EN 13430

Recovery rate of used packaging:

Total quantity recovered (in the sense of collected) packaging (whatever its final valorisation)/Total quantity packaging put on the market

Calculation of recycling rate EN 13440: 2003

$$r_{\eta} = (\delta 1 + \delta 2) / (\alpha + \beta - \gamma)$$

r_{η} = recycling rate of used packaging

$\delta 1$ = material for organic recycling

$\delta 2$ = material for material recycling

α = quantity of packaging put on the market for one way use

β = quantity of reusable packaging put on the market and used for the first time

γ = that part of used packaging which is not available for recycling due to other secondary uses

CEPI Recycling rate calculation

Recycling rate = recovered paper utilisation/ apparent paper and board consumption in Europe
Apparent consumption of paper and board in Europe is defined as internal deliveries (within CEPI) + imports from outside CEPI.

The recycling rate for 2008 was 54,6%.

In the First Declaration the recycling rate was calculated by comparing recovered paper utilisation (in paper mills inside Europe) and paper consumption. Now, recovered paper exports will also be taken into account. If recovered paper is collected in Europe and utilised for similar purposes outside Europe, this volume will be included in the utilisation.

CEPI Collection Rate

Collection Rate = used paper collection/paper and board consumption

The collection rate for 2008 was 62,6%.

tics for 2008, about 80% of the corrugated board used in Europe was collected and recycled in 2008. In a simplified system for a closed loop corrugated board packaging, this means that the percentage of recovered material is equal to $(R2 \times [1 - r_{sh}]) = 80\% \times [1 - 0,14] = 68,8\%$ of the input of the base papers would be recycled after use if all the recovered corrugated board would be recycled only within the system².

For the purposes of this document, imports and exports of the corrugated board system are ignored, as also are used packaging imports and exports. The application of this specific assumption means that the recycling rate of corrugated board (shavings + used packaging) is equal to the recovery rate of these products.

Table 3 shows that the average R1 for Europe in 2008 is about 82%. This roughly corresponds with the total amount of collected shavings and used packaging as percentage of the weight of the input of the base papers for the corrugated board production ($[q1 + q2]/\text{total paper production} = 87\%$), showing the validity of the closed-loop approach.

Note r_{sh} is not included in the calculation of the recycling rate according to the Directive on Packaging and Packaging Waste 94/62/EC and R2 does not include organic recycling as defined for the same purpose. Therefore the recycling rate differs from the rate calculated to assess compliance with the recycling targets according to the Directive.

2.3 Examples of calculation with a closed-loop approach, considering the total system

The closed-loop system assumes the ideal case that no recovered fibres are lost from the production shavings and the collected corrugated board after use, and that the fibre quality remains constant due to the reprocessing of the fibres. The primary fibre is thus recycled several times within the system.

The average fibre age is calculated as $1/(1-R2)$ where R2 = the recovery (collection) rate (defined

as the recovery rate of corrugated board after use, see definitions below figure 2). It is also assumed that the fibre age increases by 1 every time the fibres are processed through a paper machine. The first time the fibres are processed it is in a primary fibre paper mill and the subsequent times in recovered fibre paper mills (the recycling process). This means that in the system “(1-R1)” primary fibre base paper and “R1” recovered fibre base paper is used to produce corrugated boxes and a volume of $[1 - r_{sh} - (R2 \times [1 - r_{sh}])]$ of the fibres is lost as waste.

If the LCI (Life Cycle Inventory) of the primary fibre pulp and paper mill is denominated by P_{pf} the recovered pulp and paper mill by P_{rf} , the corrugated board plant by CB and waste treatment by W, the environmental impacts from the total system can be calculated as:

$$[(1-R1) \times P_{pf}] + [R1 \times P_{rf}] + CB + [1 - R2] \times W$$

If for instance the recycled pulp content rate R1 is 85%, and the recovery rate of used corrugated board packaging R2 is 80%, giving an average age of the fibres of 5, the above expression will be

$$15\% \times P_{pf} + 85\% \times P_{rf} + CB + 20\% \times W$$

The following example illustrates the use of the database and the simplified closed-loop approach (no imports/exports, no growth of the loop).

To calculate the total input and output for a corrugated box the following information is needed:

- Recovery rate (R1), indicating the recycled fibre flow in the closed-loop system
- The rate of shavings r_{sh}
- The recovery (collection) rate of used corrugated board in order to calculate the recovery rate of the paper input (R2)
- Weight of the consumed paper and glue and % liner (ln), % fluting (fl) of the total weight of the consumed paper and glue
- $\eta_{\text{corrugator}} (\approx 0,97)$
- Weight of the corrugated sheet (ws)
- Weight of the box (wb)

² In reality the volume of collected corrugated board packaging represents around 65% of the pulp used in the production of paper. The rest comes from shavings (r_{sh}), mixed grades, news magazines, high grades and primary pulp.

The principle of the calculation using the closed-loop approach is that corrugated board is built up out of the two principal grades of paper: liner and fluting. The recovery rate is used to take into account the proportion between primary fibre based paper and recycled fibre based paper in liner and fluting.

This leads to the following calculations for inputs and outputs:

for fluting: (1-R1) SCF + R1 WS
 for liner : (1-R1) KL + R1 TL

SCF (Semichemical Fluting), WS (Wellenstoff), KL (Kraftliner), TL (Testliner) and CB (Corrugated Board) are the inputs and outputs per net ton saleable product reported in the database. The data for corrugated board are only the data for the corrugated board production sites. They do not include the production of the papers that are used in the process.

Table 3.
 Base Paper Consumption for Corrugated Board in Europe 2008 (from CCB Statistics)*

Million tonnes	Fibre composition		
	Total	Primary	Recycled
Kraftliner	4,1	3,1	1,0
Testliner	7,2	-	7,2
Other recycled liner (Schrenz)	2,8	2,8	
Semichemical Fluting	0,9	0,8	0,1
Recycled-medium (Wellenstoff)	6,7	-	6,7
Total	21,7	3,9	17,8
		18%	82%

The environmental impact for the corrugated box can then be calculated as follows:

Weight x [liner production + fluting production + corrugated board production] =

$(ws/\eta_{\text{corrugator}}) \times [ln\{(1-R) KL + RTL\} + fl\{(1-R) SCF + RWS\}] + CB]$

To complete the Life Cycle Inventory information, the following are also needed:

- Transport distance of the (filled) boxes.
- Input and outputs for energy production (inputs and outputs from electricity production for the public grid, pre-combustion of natural gas etc.), transport and waste management

The fibre composition in the containerboard consumption in Europe 2008 (table 3) amounts to 3,9 million tonnes of primary fibre and 17,8 million tonnes of recovered fibre, therefore it seems reasonable to assume a recovered fibre content rate of 82%, so R1 is at least 80%.

Taking as an example the first box in table 2 (CB grammage 675 g/sqm) the inputs and outputs for the box (ws = 393 g; wb = 391 g) the calculation is as follows:

Consumption of paper and glue for the box:

	g/box	%
Kraftliner	154	37
Semichemical Fluting	239	58
Glue, starch	19	5
Total ws	412	100

Therefore liner = 37% and fluting = 58% of the weight of the corrugated board sheet.

*) The grades listed in the table 3, are treated according to the definitions in "European corrugated base papers list" published by CCB in 2008. Reference can also be made to the customs nomenclature in Commission Regulation (EC) No 1549/2006.

Filling in the data for total fossil fuel in MJ, which can be found in the Annex for the box:

$$0,412/0,97 \times [0,37\{(1-0,8) \times 2,2 + 0,8 \times 7,3\} + 0,58 \{(1-0,8) \times 5,8 + 0,8 \times 7,3\} + 1,0]$$

For a total energy input at the sites the electricity input and the fuel input have to be added up.

The average transport distances for wood and recovered paper are reported in paragraph 3.7. These data have been used to calculate the transport data in tonkm in chapter 4 and the Annex.

In paragraph 3.7 it can be seen for example that 72% of the wood that is used for Semichemical Fluting production is transported by truck over 126 km.

The wood consumption (also to be found in chapter 4 and in the Annex) is 1,04 bone dry ton wood per ton net saleable product. Since bone dry weight equals 45% of the transported weight, the transported weight of hardwood logs by truck equals $0,72 \times 1,04 \times 100/45 = 1,66$ tonnes per ton net saleable product. This is transported over 126 km, so the transport is $1,66 \times 126 = 210$ tonkm.

Assuming this is transported by a truck with a loading capacity of 40 tonnes this means that this figure has to be used in combination with data on inputs and outputs for transport by a 40t truck (for example from a generic database like Ecoinvent).

Please note that emissions from transport are not included in the "emissions to air" in chapter 4.

The amount of corrugated board that is not recycled leaves the closed-loop system and is either composted, incinerated with energy recovery, or landfilled. For the above mentioned recovery rate of at least 80% this means that of each ton of corrugated board production, 0,80 tonnes is recycled within the closed-loop system and 0,20 tonnes is lost from the system. This figure has to be used in combination with a module for waste treatment/ other recovery operations.

3. Data Description

3.1. Participating paper mills and corrugated board plants

The data in this report are based on weighted average data for 2008 of the production per ton net saleable paper and corrugated board sheets and boxes.

The data for the production of the four major paper grades: Semichemical Fluting, Kraftliner, Testliner and Wellenstoff as well as for the production of corrugated board were collected directly from the producers and checked by technical experts.

The data for Semichemical Fluting and Kraftliner represent more than 70% of the total annual production of corrugated base papers from primary fibres in Europe. The data for Semichemical Fluting and Kraftliner also represent 78% of the total consumption of these grades for corrugated board production in Europe. These paper grades are produced in large mills, located in Austria, Finland, France, Portugal, Slovakia and Sweden. Their total production was 3.706.364 tonnes net saleable paper in 2008. The mills each have an annual production of 88.000 - 669.000 tonnes net saleable paper.

The data for the production of Testliner and Wellenstoff were collected from mills, together producing about 63% (9.700.000 tonnes) of the total annual production of corrugated base papers from recovered paper in Europe. They were provided by paper mills in Austria, Czech Republic, France, Germany, Italy, the Netherlands, Spain and Great Britain. The mills each have an annual production of 36.820 - 1.122.752 tonnes net saleable paper based on 100% recovered paper.

The data on corrugated board production are based on 236 plants in Austria, Belgium, Czech Republic, Denmark, Estonia, Finland, France, Germany, Great Britain, Greece, Hungary, Ireland, Italy, Lithuania, the Netherlands, Norway, Poland, Portugal, Romania, Slovakia, Spain, Sweden and Switzerland. Together they produced 9.051.000 tonnes net saleable product, which is 42% of the total annual production of corrugated board in Europe. The production sites have an average annual production of corrugated sheets and boxes of 38.355 tonnes, varying from 6.900 – 188.300 tonnes each.

3.2. Questionnaire, definitions, allocation of inputs and outputs to different paper products produced in the same mill.

The questionnaires are available through the two Associations as a supplement to this report. A list of definitions is included in this report. The questionnaires were updated and harmonized for primary fibre based mills and recycled fibre based mills. The questionnaire included a mass balance for recovered paper mills, energy balance, water balance and carbon balance.

The questionnaire treats the paper mills and corrugated board plants as a black box, asking for annual inputs to and outputs from the mill or plant.

Differentiation between the processes within the site, such as power generation, pulping, paper production, wastewater treatment, has not been made.

For those paper mills producing more than one grade of paper it is necessary to allocate inputs and outputs to the different paper grades. Mill people who did fill in the questionnaire have done the allocation according to causality.

example:

For a mill producing both Semichemical Fluting and Kraftliner the total input of wood to the mill site has been reported as well as an allocation %-figure telling how much of the total wood consumption should be allocated to Semichemical Fluting and how much to Kraftliner.

Details on allocation are described in the following paragraphs of this chapter.

Checking of the data and the allocation percentages

The collected annual data were calculated to inputs to and outputs from the paper mills for the production of 1 ton net saleable paper for each paper product, using allocation percentages in case more than one product was produced at one mill.

The following calculation was made in most cases:

$$\frac{\text{annual in(out)put} \times \text{allocation \%}}{\text{tonnes nsp}^3 \text{ produced in 2008}}$$

Some mills have reported waterborne emissions in g/m³ waste water and for those mills the following calculation was made:

$$\frac{\text{g/m}^3 \text{ waterborne in(out)put} \times \text{allocation \%} \times \text{m}^3 \text{ water}}{\text{tonnes nsp}^3 \text{ produced in 2008}}$$

To increase the quality of the database the results were checked as follows.

The data per ton nsp for each paper product were compared by technical experts from the participating mills to investigate if variation of the data could be explained by differences in the applied technology. Data that could not be explained were rechecked to make sure that data from the individual mills were correct.

Mills were also asked to recheck the data in case any of the balances was questionable:

- C-balance in a range of + or – 10%
- Water balance: more water output than input
- Energy balance: more energy output than input and/or unrealistic energy efficiency
- For the recycled fibre based papers a mass balance of dry material inputs and outputs were calculated for the individual mills. If the input and output of material did not balance (for mass balance within a range of + or - 5%) mills were asked to investigate their data and give a corrected figure.

3.3. Weighted averages, “Best Average Environmental Practice”

The database gives the weighted averages of the inputs into and outputs from the sites per ton net saleable product (paper, corrugated board sheets and boxes) for 2008 from the participating paper mills and corrugated board plants. Annual inputs and outputs include periods of shut down, so these periods are included in the figures per ton net saleable paper.

It is important to understand that the figures do not represent a certain mill with a certain technology. On the contrary the figures represent a virtual “mill” utilising different technologies.

The technology, which is applied in the participating paper mills and corrugated board plants, is not the same.

For example: not all mills use a combined heat power generation, wastewater treatment is not always internal, a large variety of additives is used. In some cases this leads to a large variation of inputs and outputs between the mills. Also different inputs and outputs are strongly interrelated, so a mill can be high in one input compared to the others but low in another input, but a mill cannot be low or high for both. Therefore no range of the data is given to prevent that studies could be made using a false combination of highest and lowest data.

Because of confidentiality requirements by the mills it is not possible to split inputs and outputs to data per country. Weighted averages of different technologies are not so meaningful, but also for confidentiality reasons a split in applied technologies was not possible.

For this report a compromise was found for the production of Testliner and Wellenstoff as follows.

When a certain technology is used to produce Testliner and Wellenstoff by the majority of the participating mills and this technology will be used in more mills within the near future, the weighted average of the data of the mills using this technology has been calculated instead of the weighted average of all the mills. Thus the weighted averages represent a “Best Average Environmental Practice” (BAEP). Details are given in the following paragraphs of this chapter. When there is no technical reason for differences between Wellenstoff and Testliner, the weighted average of the data for both grades has been reported.

A few of the requested data could not be supplied by all the participants. In this case the weighted average may not be representative, because it is based on a limited number of data. They are marked with an *.

³ nsp: net saleable product

3.4. Material input and output

3.4.1. Material inputs

Raw Material

The wood input has been reported as total transported wood including bark and water. A pulp yield (oven dry pulp/oven dry wood) of 54-56% is normal for Kraftliner.

A high pulp yield of 80-85% is normal for Semi-chemical fluting.

The input of recovered paper has been reported as total weight including moisture and other materials (sand, metal objects, plastics, wood etc.). In European countries the water content of recovered paper is generally assumed to be about 10%. The total input of recovered paper is given but the total input is also split between the 5 main recovered paper grades according to the CEPI (Confederation of European Paper Industries) list, which conforms to the standard EN 643:

Group 1:	ordinary grades
Group 2:	medium grades
Group 3:	high grades
Group 4:	kraft grades
Group 5:	special grades.

The complete list is available on request through the Associations and CEPI.

The content of other materials in the recovered paper varies between 8 and 12%. These materials are eliminated from the pulp as rejects during the pulping. It is estimated that 25% of these materials originate from the former use of the paper, such as tags, labels etc. The remaining 75% has no relation with the former use of the paper.

The main raw material inputs for corrugated board production are different grades of paper. The liners are used for the surface layers of the corrugated board, fluting is used for the corrugated layers.

As pointed out in chapter 1 there are endless possibilities for the composition of a corrugated box. The amount of the different grades of paper and glue used as input for the corrugated board production varies accordingly. These inputs should be considered when the LCA of a certain box is studied. Examples are given in chapter 1.

This should be kept in mind when considering the averages for the paper consumption and the additives for corrugated board production in chapter 4.

Chemical inputs

Chemicals are mainly given as dry weight. If this is not the case, then it is indicated in the table in chapter 4. Data were collected for chemicals whose input exceeded 5 kg/ton net saleable product, but production sites also provided data for the most common chemicals below this limit.

Some of the chemicals have been reported grouped together after their function in the mill. One such example is lubricants that consists of a number of mineral oils, greases, fats etc. but are reported with only one figure.

The functional additives, mainly starch, influence the properties of the paper; process additives are used to guarantee that the process of paper production runs smoothly or to increase the production.

Water treatment additives include additives used for all water treatment on the site, including the treatment of water for the power station, the paper production and waste water treatment if this is done internally. The different mills use a large variety of process and water treatment additives. Those that are commonly used are mentioned in the database.

A very limited quantity of other additives, e.g. synthetic polymers (polyethylenamine, polyacrylamide, polyvinylamine) are being used.

The main input for corrugated packaging is starch glue, containing starch and small amounts (less than 0,5 kg/ton nsp) of caustic soda, borax, modified starch and wetstrength agent. Only a few plants laminate the board and/or add a protective coating. All plants that print the board use the flexo printing technique. For boxmaking cold glue and small amounts (< 0,1 kg/ton nsp) of hot melt, tape (paper or plastic), plastic tearstrip and stitch wire are used.

Packaging

All packing materials have been reported. Packaging amounts to relatively small inputs of tape, wrappings of paper or plastic film, steel bands

and pallets used as packaging of the saleable product. Pallets are used to a great extent in the logistic operations of the corrugated board industry. However the reported data on the use of pallets are confusing because of the complexity of the matter. Pallets can be returnable or one-way, only used internally in the plants and produced of wood, plastic or paper/wood combinations. Some plants have reported their use in number of pallets while others have reported in kilogram pallet per ton net saleable product. Therefore it is not meaningful to report any figure because of poor data quality.

Allocation to paper grades when a mill produces more than one paper grade

The basic data for raw material and chemical inputs are mainly based on recipes used for the production. When allocation was necessary, this was done according to mass production of the different papers.

3.4.2. Material outputs

The main output from the paper mills is of course paper. This includes about 2 kg of cores and plugs per ton paper, which are considered and weighed as part of the net saleable product. The corrugated board plants produce corrugated board and boxes.

The average moisture content of the saleable

product is 9% for Semichemical Fluting and 8 % for Kraftliner, 7,5% for Testliner and Wellenstoff, 7-8% for corrugated board.

Saleable by-products from the production of Kraftliner, are tall oil and turpentine. These are included in the report.

A saleable by-product from the production of Testliner and Wellenstoff is fuel pellets of organic substances other than wood fibres (e.g. string fibres, plastics and textiles) in recovered papers.

The pellets have the calorific value of coal and are used in large industrial ovens at temperatures above 800° C. This includes use in cement ovens, lime kilns, rock wool ovens, coal fired boilers and blast furnaces.

Residues

All residues if possible are reported as water free waste separated according to their basic nature. Residues are reported irrespectively if they are deposited internally within the site or externally, in the latter case normally at a deposition cost.

Of the residues from the recycled paper mills, mainly rejects from the pulp preparation, about 75% consist of waste that is not due to the previous use of the paper. The previous use of the paper and properties of paper cause the other 25% of the rejects: paper clips, tags, adhesive labels, fibres etc. The average dry mass of the rejects is about 55%.

Primary sludge from wastewater treatment in mills producing Testliner and Wellenstoff are recycled in the process and mostly do not leave the site.

	na	RU	LO	C	I-E	I+E	RC	LT
ashes	40%	3%	9%	22%	0%	0%	0%	27%
lubricants	31%	4%	0%	0%	0%	1%	63%	0%
fibre (primary sludge)	69%	5%	13%	5%	2%	0%	6%	0%
biological treatment sludge	34%	8%	0%	44%	0%	13%	0%	0%
rejects	46%	1%	28%	0%	0%	22%	3%	0%

na: not reported, RU: reuse, LO: landfill ordinary, C: composting, I-E: incineration without energy recovery, I+E: incineration with energy recovery, RC: recycling, LT: landfill toxic

For corrugated board the main waste stream is paper/board, which is recycled and thus should not be called waste but recyclable material.

Allocation of residues to paper grades when a mill produces more than one paper grade

Data for material outputs are based on measurements. These have to be done because the mills have to pay for landfill and incineration, or get paid for residues that are reused or recycled, like lubricants, according to the weight. When allocation was necessary, this was done according to mass of the different paper production.

There is no technical reason for differences in residues between Testliner and Wellenstoff. However the weighted averages for each paper grade do show differences because different mills are included in the samples. To prevent misunderstanding, the same amounts for residues for both paper grades are reported as their weighted average.

3.5. Energy input and output

Fuel inputs to the sites have been reported in GJ. The lower calorific heat values have been used to calculate GJ from m³ or tonnes of fuel. Fossil fuel and biomass fuel have been reported separately. The energy figures for the sites include both energy for process and energy for infrastructure. No attempts have been made to differentiate between these two types of energy usage because process energy is so totally dominating (98% or more).

Input of electricity into the sites is also reported. The electricity that is produced at the site itself is not reported. Some mills are selling energy externally in the form of electricity, steam or warm water. This is reported separately.

The production sites are treated as a black box in the database, giving data on inputs and outputs only. Because no information is given about what happens within the box it is not possible to calculate an energy balance with the data in the database.

Within this box, energy is recovered through the burning of black liquor and bark from the wood coming in at production sites for primary fibre

based paper production. Most of the energy used in the process for Kraftliner production comes from internal burning of the black liquor. This inherent energy is not reported as part of the fuel input. The total energy input for the process for Kraftliner production including the black liquor burning is around 15 GJ/ton. The total energy input for the process of Semichemical Fluting production is around 12 GJ/ton. Energy from internal incineration of rejects at the site is also not reported as part of the energy input.

Combined heat power generation is applied at the production sites for recycled fibre based paper, but not always in the same way. The combined heat power generation can cover all or part of the steam consumption (figure 3). When it covers only part of the steam consumption, then additional boilers also produce steam.

The process always uses more heat (steam) than electricity. Therefore, when the installation is designed to cover the whole steam consumption more electricity is generated than what is needed for the process. The excess of electricity is sold to the public grid.

There are two possibilities of treating this excess electricity in an LCA.

a. The production of electricity is an integral part of the paper production: it would not be produced if the paper were not produced. Paper is thus considered as the only "product" of the process. In an LCA this would mean that electricity generation for the public grid is "saved" when an excess of electricity is produced at a paper mill is sold to the public grid. Thus environmental inputs and outputs are saved since combined heat power installation produces electricity with a higher efficiency than the public grid.

b. Another possibility is to consider the paper and excess electricity as co-products. Paper and electricity are then both "products" from the process. In an LCA this would require allocation of inputs and outputs to both products.

The first possibility seems to be the most frequently applied. Also the quality of the measured data is better than the data that are the result of the allocation between paper production and electric-

ity that is sold to the public grid. Therefore the inputs and outputs for paper production that are reported include the production of electricity that is sold to the public grid. The data do not include savings on electricity production elsewhere. These depend on the electricity module that is used in combination with the database.

The weighted average for mills using combined heat power generation (65% of production volume of the the participating mills producing Wellenstoff and Testliner) is given for the input of fuels and corresponding emissions to the air. These figures are regarded to represent BAEP (Best Average Environmental Practice).

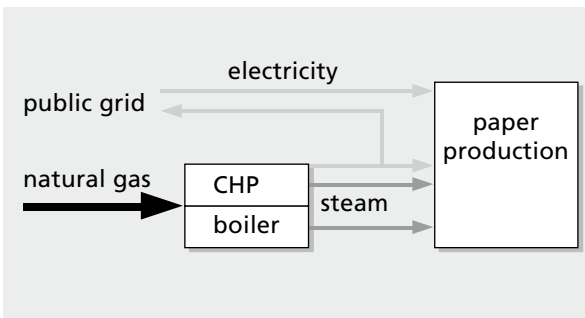

Figure 3. CHP, combined heat power generation

Diesel or gasoil/LPG used for internal transports are reported.

Most of the energy consumed by the mills producing Kraftliner are by-products from the process and thus originates from the trees i.e. have biomass origin.

Allocation of energy to paper grades when a mill produces more than one paper grade

The energy is measured, because it is paid for. Allocation for fuels and electricity input is calculated according to energy (heat and electricity) required for the production of the different paper grades. Allocation of the other fuels, such as diesel oil used for internal transportation, was calculated according to mass production of each paper grade.

There is no technical reason for differences in energy consumption between Testliner and Wellenstoff. However the weighted averages for each paper grade do show differences because different mills are included in the samples. To prevent misunderstanding, the same amounts for energy consumption and emissions to air for both paper grades are reported as their weighted average.

3.6. Water inputs and outputs

When paper mills use water, they do not consume this water during the production process. After (re)use it is returned to the rivers, lakes or seas as cooling water and purified effluent water. A limited amount of water is evaporated (about 1-1,5 m3/ton nsp) in the drying section of the paper production.

The water debate focuses on the impact of water consumption. This is best reflected in the local water availability rather than in the amount of water taken into the mills. Therefore, the appropriate indicator is the net difference of water taken in and water returned to the rivers or lakes (water consumed, not taken in).

3.7. Transport

The transport distances of wood raw materials from the harvesting sites in the forests to the mills have been reported separately for trucks, rail and ships. The trucks and rail wagons are normally loaded to full capacity but go back empty. The trucks seem to carry 40-44 tonnes of wood but the figures are uncertain because many mills were unable to give any information.

For recovered paper the transport distances from recovered paper dealer to the mills have been reported. Generally the lorries are loaded to full capacity. On the return trip it is estimated that 40% of the trucks return empty.

Transport raw material		Semichemical Fluting	Kraftliner	Wellenstoff and Testliner
wood by truck	km	126	113	
	%	72	84	
wood by rail	km	265	269	
	%	27	5	
wood by boat	km	310	2571	
	%	1	11	
recovered paper by truck	km	283	436	216
	%	77	51	98,1
recovered paper by rail	km	307	873	192
	%	23	36	1,8
recovered paper by boat	km		1187	2475
	%		13	0,1

These data have been calculated to tonkm for chapter 4 and the Annex.

Transport of the residues was not included in the questionnaire as this was seen to be part of the residue treatment. During the discussions with the technical experts it became clear that the transport of rejects is mainly to near by landfill, 3-30 km.

Allocation of transports to paper grades when a mill produces more than one paper grade

No record is kept by the mills to register this kind of information, so the data are based on estimations.

Transport distances and means of transports of raw paper materials to the corrugated board plants are not included in chapter 4. The range of the collected data is so large, that establishing average data is not meaningful. The complexity is due to the fact that raw paper materials from very many different suppliers are used in a corrugating plant. In practice this should be considered case-by-case.

Internal transport is included in the energy input (paragraph 3.5).

3.8. Emissions to air

Emissions from fuel combustion (transport, electricity generation for the public grid) outside the mill are not included in the data.

Emissions to air from the sites have been reported. For dust, TRS (H₂S), NO_x and SO_x the figures from the paper mills are mostly based on measurements. For CO₂ the figures reported are based on calculations and reported separately for fossil and biomass origin.

Corrugated board plants have no measured air emission data to report. Therefore the air emission figures for corrugated board production reported in chapter 4 and in the Annex are calculated from reported figures for consumption of different fuels in the corrugated board plants. The emission factors in table 4 were used for the calculations.

	unit	natural gas	oil heavy	oil light/diesel
CO ₂ (fossil) ^{1*}	kg/GJ	56	78	74
CO ^{2*}	g/GJ	2,1	7	4
Dust ^{2*}	g/GJ	0,2	50	0,1
NO _x (as NO ₂) ^{2*}	g/GJ	18	100	50
SO _x (as SO ₂) ^{2*}	g/GJ	0,55	400	47
ecoinvent dataset name and ID-number		natural gas, burned in industrial furnace >100kW, RER, [MJ] (#1363)	heavy fuel oil, burned in industrial furnace 1MW, non-modulating, RER, [MJ] (#1589)	light fuel oil, burned in industrial furnace 1MW, non-modulating, RER, [MJ] (#1601)

^{1*} Source Intergovernmental Panel on Climate Change ^{2*} ecoinvent Centre, ecoinvent data v1.2 with corrections, Final reports ecoinvent 2000 No. 1-16, Swiss Centre for Life Cycle Inventories, ISBN 3-905594-38-2, Duebendorf, CH, www.ecoinvent.org, 2006

Table 4. Default factors for calculating emissions to air.

Emissions to air in the flue gas from the power station are given for the mills producing Testliner and Wellenstoff that use combined heat power generation. Emissions from incineration of rejects with energy recovery at the mill are included.

Emissions in the steam from the drying section of the paper machines are not included.

When mills have anaerobic wastewater treatment on the site, biogas originating from this process is used as a fuel by the mill. The emissions to air originating from the use of biogas as fuel are included.

Volume of the total flue gas stream was not asked in the questionnaire or the means of flue gas treatment.

Some mills producing Semichemical Fluting and Kraftliner could report emissions of CO but most of the mills were unable to give reliable information and therefore CO figures have been omitted for those two paper grades.

The mills were unable to report any figures for emissions like N₂O, NH₃, CH₄, aldehydes, Pb, Hg etc. because there are no measurements. Databases on energy production can be used to get an indication of the emissions that can occur due to combustion of different fossil fuels. Together with the amount of fossil fuels used in the processes (chapter 4 and the Annex), an estimate can be made of the order of magnitude of these

emissions. These substances are not expected to be emitted from integrated pulp and paper mills based on wood as a raw material.

Allocation of emissions to paper grades when a mill produces more than one paper grade

Emissions to air are calculated from measurements, applied technology, permit values or from the input of fuels. Necessary allocation was done in the same way as for energy input.

3.9. Emissions to water

Water that is taken in has to be treated before it is used in the process, and it is again treated after the process before it is released as effluent to a recipient. The substances in the effluent after wastewater treatment are reported.

All mills have some sort of effluent water treatment either mechanical treatment by sedimentation or in addition also biological anaerobic and aerobic or chemical treatment of the effluent.

A few mills send their effluent water to an external communal treatment plant.

The volume of effluent water is reported separately for polluted (chemically polluted effluent) and non polluted (including thermally polluted effluent, e.g. cooling water). All mills have reported the figures for outgoing effluent water to the recipient i.e. effluent water after final treatment.

The amount of substances (COD, BOD, suspended solids) per m³ of effluent from the different mills show very little variation when the efficiency of the waste water treatment station is the same. The amount of substances per ton paper production may however vary according to the amount of effluent, depending on specific circumstances in the paper production process in the different mills.

In the questionnaire for data collection in 2005, a number of other emissions were asked for like oils, nitrates, acids, AOX, chlorate, chlorides, borates, phenol, Hg, Pb etc. Few mills were able to report figures probably because there are no or too few measurements. Only COD, BOD₅, suspended solids, total nitrogen and total phosphorus are based on data from most mills in addition to the total volume of effluent waters.

For the production of Testliner and Wellenstoff the weighted average of the mills with internal waste water treatment using biological anaerobic and aerobic waste water treatment with a high efficiency (>95% for COD, > 99% for BOD₅, > 90% for suspended solids) and mills with zero effluent are given (82% of the production volume of the participating mills)..

Due to the water treatment it is possible that the content of certain substances per m³ is higher if the water is taken in from a river than in the effluent to the river. In an LCA

this would mean that in this case the production of paper could be credited for the reduction in substances. This is illustrated in figure 4. However since only a few mills analyse their incoming water the available data cannot be considered as representative. Therefore only data for the emissions to the recipient are given, without taking into account the substances in the incoming water.

Most of the corrugated board plants have internal waste water treatment. The data are related to effluent after internal waste water treatment and before external treatment.

Besides the substances reported in chapter 4 and the Annex, very few plants have also given data on some of the following emissions: metals (Cadmium, Chromium, Lead, Nickel, Iron, Boron, Aluminium), AOX, Chlorine and Phosphorus. The amounts are below 0,001 kg/ton nsp.

Allocation of emissions to paper grades when a mill produces more than one paper grade

As far as waterborne emissions per m³ are measured for a mill, these data are well documented.

The figures reported are based normally on continuous measurements according to control programs set by official authorities. Given emissions to water are measured according to standard methodology.

Where necessary, allocation between paper grades is done according to mass of produced paper grade. There is no technical reason for differences in water consumption, effluent and emissions to water between Testliner and Wellenstoff. However the weighted averages for each paper grade do show differences because different mills are included in the samples. To prevent misunderstanding, the same amounts for water consumption, effluent and emissions to water for both paper grades are reported as their weighted average.

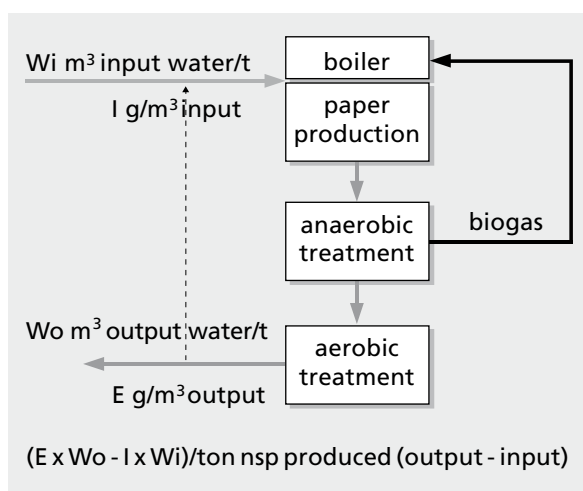

W_i : input water in m³

W_o : output water in m³ (effluent)

I : amount of substances in input water

E : amount of substances in output water

Fig. 4 Credit for reduction of substances in the in effluent water

4. Data

The table shows the calculated inputs and outputs for the production of 1 ton of corrugated board in Europe with an average paper grade composition. The average paper grade composition that was used is reported in chapter 2, table 3. The original five datasets for the four main paper grades and corrugated board production from which the data are derived, are reported in the Annex.

Averages are only given for parameters that were available from all 5 data sets. The average for starch, sodium hydroxide (NaOH), water based flexo ink and sulphuric acid (H₂SO₄) are given as they are the main additives by weight.

PRODUCT	ton corrugated board sheet	1
SOLD BYPRODUCTS		
Electricity	GJ/ton nsp	0.55
Thermal energy	GJ/ton nsp	0.14
Fuel pellets	kg/ton	2.61
Tall oil	kg/ton	3.7
Turpentine	kg/ton	0.21
RAW MATERIAL		
Wood consumption <i>as bone dry weight (= 45% of transported total wet weight)</i>		
Softwood logs	ton/ton nsp	0.16
Hardwood logs	ton/ton nsp	0.078
Saw mill residues, softwood	ton/ton nsp	0.076
Saw mill residues, hardwood	ton/ton nsp	0.0062
<i>Total wood</i>	ton/ton nsp	0.32
Recovered Paper <i>as wet weight</i>		
Category		
1	ton/ton nsp	0.72
2	ton/ton nsp	0.007
3	ton/ton nsp	0.0036
4	ton/ton nsp	0.15
5	ton/ton nsp	0.0047
<i>Total recovered paper</i>	ton/ton nsp	0.88
Purchased pulp consumption <i>as bone dry weight</i>		
Bleached pulp	ton/ton nsp	0.0055
Unbleached pulp	ton/ton nsp	0.00037
Paper consumption for corrugated board production		
Total	ton/ton nsp	1.09
Others		
Cores	kg/ton nsp	2.2
Core plugs	kg/ton nsp	0.049
TRANSPORT OF RAW MATERIALS		
Wood		
Wood with truck	tonkm	66
Wood with rail	tonkm	15
Wood with boat	tonkm	170
Recovered paper		
Recovered paper with truck	tonkm	187
Recovered paper with rail	tonkm	18
Recovered paper with boat	tonkm	10

ENERGY INPUTS

Steam bought	GJ/ton nsp	0.048
Fossil fuels		
Natural gas	GJ/ton nsp	6.3
Heavy fuel oil	GJ/ton nsp	0.26
Light fuel oil	GJ/ton nsp	0.10
Diesel oil	GJ/ton nsp	0.038
LPG	GJ/ton nsp	0.031
Coal	GJ/ton nsp	0.28
Lignite	GJ/ton nsp	0.22
Peat	GJ/ton nsp	0.09
<i>Total fossil fuel</i>	GJ/ton nsp	7.3
Renewable fuels		
Biofuel (bark, scrap wood, tall oil)	GJ/ton nsp	0.26
<i>Total renewable fuel</i>	GJ/ton nsp	0.26
<i>Total fuel</i>	GJ/ton nsp	7.6
Electricity		
Bought Electricity	GJ/ton nsp	1.15

WATER

Water input		
Ground water	m3/ton nsp	2.0
Surface water	m3/ton nsp	11.3
Network water drinkable	m3/ton nsp	0.43
Network water non drinkable	m3/ton nsp	0.02
<i>Total</i>	m3/ton nsp	13.7
Water output		
Thermally polluted	m3/ton nsp	3.4
Chemically polluted	m3/ton nsp	8.8
<i>Total</i>	m3/ton nsp	12.2
<i>Water input - water output</i>	m3/ton nsp	1.50

ADDITIVES, dry mass

H2SO4	kg/ton nsp	2.2
Water based ink for flexo printing	kg/ton nsp	2.5
NaOH	kg/ton nsp	3.8
Starch, corn	kg/ton nsp	25.5
Starch, potato	kg/ton nsp	2.1
Starch, wheat	kg/ton nsp	19.3
Starch, other	kg/ton nsp	4.6
Starch, modified	kg/ton nsp	4.5

PACKAGING MATERIALS

Paper, board	kg/ton nsp	7.5
PE	kg/ton nsp	0.35
Steel	kg/ton nsp	0.21
Strapping	kg/ton nsp	0.51

EMISSIONS TO AIR

Dust	kg/ton nsp	0.075
CO2 (fossil)	kg/ton nsp	440
CO2 (biomass)	kg/ton nsp	330
NOx (as NO2)	kg/ton nsp	0.73
SOx (as SO2)	kg/ton nsp	0.17

EMISSIONS TO WATER

COD	kg/ton nsp	3.0
BOD 5	kg/ton nsp	0.73
Suspended solids	kg/ton nsp	0.57

RESIDUES

Bark, wood	kg/ton nsp	3.4
Calcium Carbonate	kg/ton nsp	0.74
Inorganic ashes (10 01 01)	kg/ton nsp	5.7
Inorganic sludges	kg/ton nsp	1.2
Organic sludges (03 03 01 and 03 03 11)	kg/ton nsp	18.0
Paper, board, recycled	kg/ton nsp	148
Plastics	kg/ton nsp	0.12
Rejects, paper related	kg/ton nsp	8.9
Rejects, other	kg/ton nsp	27.0

5. Final Remarks

Both associations consider the project to be of major importance. To assure the maintenance of the database a Reference Group has been formed, with representatives from FEFCO and CCB. The main task of this Reference Group is to initiate updates and evaluate and develop the use of the database.

Cradle-to-grave datasets will be developed, including upstream and downstream processes as described in chapter 2. These will be made available from the FEFCO website, www.fefco.org.

5.1. Updates

In the future a regular update of the database will be made, allowing an adaptation of the database to new developments in LCA standards.

The next update of the report is foreseen for 2012, containing data for 2011.

6. Definitions

Allocation	Technique for partitioning the inputs and outputs of a system amongst products
Effluent	Water leaving the mill after treatment
Incineration + energy	Incineration of residues with energy recovery
Fluting	Paper grades used for the corrugated layer of corrugated board
Functional additives	Additives that influence the properties of paper
Liner	Paper grades used for the surface layer of corrugated board
Life Cycle Assessment	Compilation and evaluation, according to a systematic set of procedures, of the inputs and outputs and the potential environmental impacts of a product system throughout its life cycle
Life Cycle Impact Assessment	Phase of the life cycle assessment aimed at understanding and evaluating the magnitude and significance of the potential environmental impacts of a product system
Life Cycle Inventory Analysis	Phase of the life cycle assessment involving compilation, and the quantification of inputs and outputs, for a given product system throughout its life cycle
Packaging materials	Materials bought and used for the packaging of the saleable product (wrappings, pallets)
Primary Fibre	Virgin fibre, fibres that have not been recycled before use in paper production
Process additives	Additives that are used to guarantee that the process of paper production runs smoothly or to increase the production
Rejects	Other material in recovered paper, which is eliminated during the pulp preparation
Transport distance of recovered paper	Distance from recovered paper supplier to the paper mill
Transport distance of wood	Distance from harvesting site to the paper mill
Wellenstoff	Recovered fibre-based Fluting

Annex

PRODUCT	ton net saleable	Semichemical Fluting	Kraftliner	Wellenstoff	Testliner	Corrugated Board
		1	1	1	1	1
SOLD BYPRODUCTS						
Bark						
Tall oil	kg/ton	0	19.6	0	0	0
Turpentine	kg/ton	0	1.1	0	0	0
Fuel pellets	kg/ton	0	0	3.4	3.4	0
Electricity	GJ/ton nsp	0.060	0.046	0.70	0.70	0
Thermal energy	GJ/ton nsp	0.72	0.53	0.01	0.01	0
RAW MATERIAL						
Wood consumption <i>as bone dry weight (= 45% of transported total wet weight)</i>						
Softwood logs	ton/ton nsp	0.05	0.81	0	0	0
Hardwood logs	ton/ton nsp	0.84	0.23	0	0	0
Saw mill residues, softwood	ton/ton nsp	0.0047	0.40	0	0	0
Saw mill residues, hardwood	ton/ton nsp	0.15	0	0	0	0
<i>Total wood</i>	ton/ton nsp	1.04	1.44	0	0	0
Recovered Paper <i>as wet weight</i>						
Category						
1	ton/ton nsp	0.091	0.21	0.940	0.909	0
2	ton/ton nsp	0	0	0.001	0.014	0
3	ton/ton nsp	0	0	0	0.0079	0
4	ton/ton nsp	0.057	0.042	0.12	0.14	0
5	ton/ton nsp	0	0	0.007	0.006	0
<i>Total recovered paper</i>	ton/ton nsp	0.15	0.25	1.07	1.08	0
Purchased pulp consumption <i>as bone dry weight</i>						
Bleached pulp	ton/ton nsp	0	0.029	0	0	0
Unbleached pulp	ton/ton nsp	0.0090	0	0	0	0
Paper consumption for corrugated board production						
Total	ton/ton nsp	0	0	0	0	1.09
Cores	kg/ton nsp	2.9	1.6	2.2	2.4	0
Core plugs	kg/ton nsp	0.045	0.064	0.04	0.05	0
TRANSPORT OF RAW MATERIALS						
Wood						
Wood with truck	tonkm	210	302	0	0	0
Wood with rail	tonkm	165	43	0	0	0
Wood with boat	tonkm	7.2	899	0	0	0
Recovered paper						
Recovered paper with truck	tonkm	32	56	228	228	0
Recovered paper with rail	tonkm	10	80	4	4	0
Recovered paper with boat	tonkm	0	39	3	3	0

		Semichemical Fluting	Kraftliner	Wellenstoff	Testliner	Corrugated Board
ENERGY INPUTS						
Steam bought	GJ/ton nsp	0	0	0	0	0.05
Fossil fuels						
Natural gas	GJ/ton nsp	0	1.6	6.81	6.81	0.77
Heavy fuel oil	GJ/ton nsp	1.4	0.52	0.00081	0.00081	0.10
Light fuel oil	GJ/ton nsp	0.018	0.13	0.00046	0.00046	0.071
Diesel oil	GJ/ton nsp	0.022	0.0079	0.0061	0.0061	0.031
LPG	GJ/ton nsp	0	0	0.000052	0.000052	0.031
Coal	GJ/ton nsp	2.3	0	0.24	0.24	0
Lignite	GJ/ton nsp	0	0	0.29	0.29	0
Peat	GJ/ton nsp	2.1	0.0071	0	0	0
<i>Total fossil fuel</i>	GJ/ton nsp	5.84	2.26	7.35	7.35	1.00
Renewable fuels						
Biofuel (bark, scrap wood, tall oil)	GJ/ton nsp	1.7	0.95	0	0	0.0057
<i>Total renewable fuel</i>	GJ/ton nsp	1.70	0.95	0	0	0.0057
<i>Total fuel</i>	GJ/ton nsp	7.54	3.21	7.35	7.35	1.01
Electricity						
Bought Electricity	GJ/ton nsp	1.43	1.98	0.41	0.41	0.40
WATER						
Water input						
Ground water	m3/ton nsp	0.13	0	2.44	2.44	0.078
Surface water	m3/ton nsp	56	33.4	3.42	3.42	0.027
Network water drinkable	m3/ton nsp	na	0.10	0.07	0.07	0.35
Network water non drinkable	m3/ton nsp	0	0	0.02	0.02	0
<i>Total</i>	m3/ton nsp	56.1	33.5	6.0	6.0	0.46
Water output						
Thermally polluted	m3/ton nsp	22.6	12.5	0.1	0.1	0
Chemically polluted	m3/ton nsp	31.9	20.3	4.4	4.4	0.19
<i>Total</i>	m3/ton nsp	54.5	32.8	4.6	4.6	0.19
<i>Water input - water output</i>	m3/ton nsp	1.6	0.7	1.4	1.4	0.3
ADDITIVES, dry mass						
Alum (Al ₂ (SO ₄) ₃)	kg/ton nsp	-	10.3	0	0	0
Biocides	kg/ton nsp	-	0.064	0.14	0.14	-
CaCO ₃	kg/ton nsp	-	2.9	-	-	0
CaO	kg/ton nsp	0.97	6.4	-	-	0
Coagulant	kg/ton nsp	-	0.17	-	-	0

		Semichemical Fluting	Kraftliner	Wellenstoff	Testliner	Corrugated Board
Colorants	kg/ton nsp	0	0.089	0.02	0.65	0
CO2	kg/ton nsp	-	1.1	-	-	0
Defoamer	kg/ton nsp	0.11	1.3	0.16	0.16	0
Fillers	kg/ton nsp	0	20.9	0.57	0.53	0
Glue, cold + hot melts	kg/ton nsp	0	0	0	0	1.2
H2O2, peroxide	kg/ton nsp	0	4.7	0	0	0
H3PO4	kg/ton nsp	-	-	-	-	0
H2SO4	kg/ton nsp	0.48	11.6	-	-	0
HCl	kg/ton nsp	0.29	0.30	-	-	0
Water based ink for flexo printing	kg/ton nsp	0	0	0	0	2.5
Lubricants	kg/ton nsp	0.14	-	0.23	0.23	-
NaClO3	kg/ton nsp	0	1.3	0	0	0
Na2CO3 (soda)	kg/ton nsp	2.0	2.1	-	-	0
Na2SO4	kg/ton nsp	0	1.9	0	0	0
NaOH	kg/ton nsp	16.9	10.0	0.34	0.22	0
NH3	kg/ton nsp	8.7	0.26	-	-	0
Oxygen, O2	kg/ton nsp	0	1.4	0	0	0
Pitch despergents	kg/ton nsp	-	0.010	0.24	0.24	0
Retention agents	kg/ton nsp	0.89	1.3	1.41	1.41	0
S	kg/ton nsp	8.3	0	0	0	0
Sizing agents	kg/ton nsp	-	2.3	0.022	1.7	0
SO2	kg/ton nsp	1.8	-	0	0	0
Starch, corn	kg/ton nsp	0	2.2	16.6	19.1	11.2
Starch, potato	kg/ton nsp	0	3.1	2.5	1.3	0.2
Starch, wheat	kg/ton nsp	0	2.4	21.0	15.9	5.1
Starch, other	kg/ton nsp	0	0	1.5	1.6	3.4
Starch, modified	kg/ton nsp	0	4.9	0.7	0.8	3.0

PACKAGING MATERIALS

Pallet	kg/ton nsp	0	0	0.01	0.01	na
Paper, board	kg/ton nsp	2.6	0.19	0	0	7.3
PE	kg/ton nsp	0.01	0	0.02	0.02	0.34
Steel	kg/ton nsp	0.02	0.01	0.05	0.05	0.17
Strapping	kg/ton nsp	0	0	0	0	0.51

EMISSIONS TO AIR

Dust	kg/ton nsp	0.16	0.31	0.00088	0.00088	0.0088
CO2 (fossil)	kg/ton nsp	520	137	430	430	61.3
CO2 (biomass)	kg/ton nsp	615	1516	24	24	0
CO	kg/ton nsp	2.8	na	0.06	0.06	na
NOx (as NO2)	kg/ton nsp	1.3	1.1	0.57	0.57	0.030
SOx (as SO2)	kg/ton nsp	1.5	0.14	0.050	0.050	0.046
TRS (H2S as S)	kg/ton nsp	0.065	0.037	0	0	0

		Semichemical Fluting	Kraftliner	Wellenstoff	Testliner	Corrugated Board
EMISSIONS TO WATER						
COD	kg/ton nsp	6.9	9.4	0.78	0.78	0.34
BOD 5	kg/ton nsp	0.45	2.9	0.074	0.074	0.11
TOC	kg/ton nsp	2.8	1.7	na	na	na
Suspended solids	kg/ton nsp	1.0	1.4	0.23	0.23	0.086
Total Nitrogen	kg/ton nsp	0.50	0.2	0.041	0.041	na
Ammonia	kg/ton nsp	na	na	0,016*	0,016*	na
AOX	kg/ton nsp	na	0.0031	0,00062*	0,00062*	na
Total Phosphorus	kg/ton nsp	0.022	0.024	0.0051	0.0051	na
Chlorides	kg/ton nsp	na	na	0,76*	0,76*	na
Cu	kg/ton nsp	na	na	0,000027*	0,000027*	0,0015*
Zinc	kg/ton nsp	na	na	0,00012*	0,00012*	0,00075*
pH (year average)	pH	na	na	7.6	7.6	na
Temperature (year average)	oC	na	na	25.6	25.6	na
RESIDUES						
Bark, wood	kg/ton nsp	1.7	9.0	0	0	1.6
Calcium Carbonate	kg/ton nsp	0.01	3.9	0	0	0
Ink residues	kg/ton nsp	0	0	0	0	1.7
Inorganic ashes (10 01 01)	kg/ton nsp	28.4	9.0	3.7	3.7	0
Inorganic sludges	kg/ton nsp	2.0	6.1	0	0	0
Organic sludges	kg/ton nsp	4.8	4.1	20.0	20.0	1.6
Paper, board, recycled	kg/ton nsp	0	0	0	0	148
Plastics	kg/ton nsp	0	0	0	0	0.38
Rejects, paper related (03 03 07)	kg/ton nsp	1.2	2.1	11.0	11.0	0
Rejects, other (03 03 07)	kg/ton nsp	3.5	8.3	32.9	32.9	0
Starch, glue (wet weight)	kg/ton nsp	0	0	0	0	0.23
Lubricants and oil	kg/ton nsp	0.070	0.09	0.12	0.12	0.046

* = not representative

"-" = not reported, below reporting requirements see "chemical input"

na = not available

nsp = net saleable product

**Please check
if this is the most recent report**



FEFCO

Avenue Louise 250
BE-1050 Brussels
Tel: +32 2 646 40 70
Fax: +32 2 646 64 60
E-mail: info@fefco.org
www.fefco.org

Cepi ContainerBoard

Avenue Louise 250
BE-1050 Brussels
Tel: +32 2 647 41 57
Fax: +32 2 647 17 24
E-mail: ccb@ecbo.be
www.cepi-containerboard.org